

V3D - VLD - VHD
inverter - inverter - inverter

frequency converters instruction manual



procon
HAJTÁSTECHNIKA



► TABLE OF CONTENTS

APPLICATION 4

FUNCTIONING 4

GENERAL FEATURES 5

DECLARATION OF CONFORMITY 5

MECHANICAL INSTALLATION 6

TEST RUN 7

Cables and fuses 8

Main and Control Circuit Wiring 9

 Connecting the power line 9

 Connecting the motor 9

 Connecting the protective earth 9

 Connecting the control circuitry 9

PUTTING IN OPERATON THE FREQUENCY CONVERTER FOR THE FIRST TIME 10

ASSIGNMENT AND CONNECTION OF THE V3D TERMINAL BLOCK 11

Jumper settings 12

Connections of the incremental rotation speed encoder (IRE) and thermal protection of the motor 12

Connecting the brake resistor 13

Connecting a two-wire (4÷20mA) remote transmitter 13

ASSIGNMENT AND CONNECTION OF THE VLD / VHD TERMINAL BLOCK 14

Jumper settings 15

High voltage terminal block 15

Connections of the incremental rotation speed encoder (IRE) and thermal protection of the motor 16

Connecting the brake resistor 16

Connecting a two-wire (4÷20 mA) remote transmitter 17

±10 V analogue input 17

OPERATING THE CONVERTER 18

Programming terminal 18

Operating from the computer 18

Controlling terminal 19

 Functions of the push buttons 19

PROGRAMMING 20

Programming procedure 20

Quick menu 20

DRIVING TECHNOLOGY SUPPLEMENTS 21

4x16 character display 21

Potentiometer 21

Selection of the brake resistors at dynamic braking 21

MAINTENANCE 22

GUARANTEE AND REPAIR 22

DISPOSAL 22

FREQUENCY CONVERTER SELECTION GUIDE 23

PERIPHERAL EQUIPMENT SELECTION GUIDE 24

NOTES 25

Dear Customer!

Thank you for having decided in favour of PROCON Ltd's frequency converter.

This Instruction Manual contains all information necessary for starting up and operating the frequency converter. Read this manual before installing the frequency converter.

Follow all safety measures, warnings and instructions described in this manual.

The manufacturer bears no responsibility for any personal injury and/or material damage arising from not taking into consideration the warnings in this manual.

At receiving the frequency converter, please check up followings:

- Make sure that the frequency converter is not damaged. If you detect any damage of the frequency converter contact the manufacturer.
- Check the data plate of the device to make sure that you received the ordered model. If not, please contact the manufacturer

Following graphic symbols will be used in this manual:



This symbol is used for those instructions whose negligence could cause electric shock, severe injury or even death.



This symbol is used for those instructions whose negligence could cause fire and injury.



This symbol is used for those instructions whose negligence could cause personal injury, damage in the equipment and property damage.



Important information

► APPLICATION

The V3D, VLD and VHD series frequency converters are digitally programmable appliances.

They are suitable for the near loss-free regulation of the rotation speed of any type of three-phase asynchronous motors with squirrel-cage rotor from 0.55 kW to 250 kW power ratings, at 400 V.

The converters comply with the requirements of the standards relating to control devices for use in the electric industry.

► FUNCTIONING

The alternating voltage from the power line is rectified by a line diode bridge, then electrolytic capacitors smooth out the pulsating voltage. The intelligent IGBT end stage, driven with sinusoidal modulated pulses, delivers to the motor a voltage of variable amplitude and frequency. Following the description of the programming, until the motor reaches its nominal revolution the voltage vs. frequency relation can optionally be changed, according to the character of the load. (Linear, quadratically modified or knee point characteristics can be programmed.)

At low frequencies the ohmic resistance of the motor winding can be compensated by setting the U boost voltage.

Below the nominal revolution the frequency converter is capable of delivering nominal torque; beyond it the converter delivers constant power.

In case of built-in dynamic brake, the converter can be equipped with a braking resistor.

► GENERAL FEATURES

Line voltage	3 x 380 ÷ 440 V AC ± 10 %
Line frequency	50 ÷ 60 Hz (sine wave)
Motor voltage	3 x 0 ÷ actual value of the input voltage (PWM modulated sine wave)
Motor frequency	0 ÷ 1000 Hz (free programmable)
Protection grade	IP20 (optionally IP54)
Line filter	 CAUTION The device is equipped with an industry-standard interference suppressor only! For residential use, an external interference suppressor, metal box installation and shielded motor cable are required. Please ask the manufacturer's opinion.
Ambient temperature	0°C ÷ +40 °C
Relative humidity	maximum 90 % (non-condensing)
Storage temperature	-20 °C ÷ +60 °C
Requirements for the place of the installation	Install the drive in an area free from: <ul style="list-style-type: none"> ▪ oil, oil mist, dust, metal shavings, water or other foreign materials, ▪ combustible materials (e.g., wood), ▪ harmful gases and liquids, ▪ excessive vibration, ▪ chlorides, ▪ direct sunlight
Orientation	The frequency converter must always be mounted in vertical position, with provision for the ventilation requirements.

► DECLARATION OF CONFORMITY

The frequency converters have been manufactured with considering following directives:

Machinery directive	2006/42/EK
Low voltage directive	2014/35/EU
Electromagnetic Compatibility (EMC) directive	2014/30/EU
Safety of machinery	EN 13849-1:2008
Insulation coordination	EN 60664-1:2008
EMC Immunity for industrial environments	EN 61000-6-2:2007
EMC Emission standard for industrial environments	EN 61000-6-4:2007

 CAUTION
<p>These products serve for being mounted into machineries. These products are allowed to be put into service only after the machinery comprising the product was found to comply with the above directives about machineries.</p>
<p>According to the directions on electromagnetic compatibility (EMC) the listed products are not considered as products which can be operated alone. The electromagnetic compatibility can only be evaluated after the product was incorporated in the whole system. Certification of this evaluation refers not to the stand-alone product but to the complete machinery.</p>

► MECHANICAL INSTALLATION

The appliance belongs to protection class IP-20 and is allowed to be operated as a built-in unit only.

Should the appliance need increased protection due to the conditions (water, dust, aggressive materials), use at least protection IP-54. If the appliance is installed by the user, the issues cooling and arranging the cables need to be consulted with the manufacturer.

⚠ CAUTION

The manufacturer takes no responsibility for damages caused by incorrect installation.

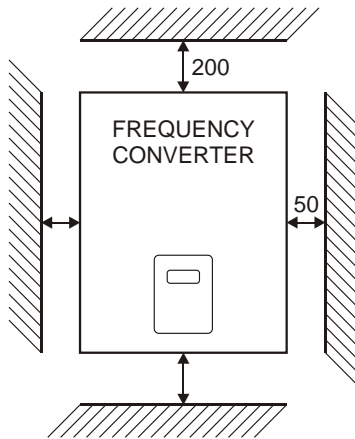

- Beside the side walls at least 50mm, below and above the unit at least 200 mm free space must be provided.
- If the device is built in closed control cabinet, overheating of the inside room must be prevented with proper ventilation!
- The slots for fresh air and used air must be held free to assure proper ventilation. The filters of the slots must be cleaned regularly!
- At IP54 versions the cooling is facilitated with heatsinks of increased size that must be placed outside the cabinet, with maintaining the IP54 protection!
- On demand the manufacturer builds the equipment in a cabinet of proper size.
- At types with forced ventilation the inlet openings should be on the bottom side, the ventilated outlets on the upper side (possible diagonally)

► **TEST RUN**

In the course of the installation and test run the manufacturer's attached wiring instructions and the instructions of the effective standards must be complied with.

 **CAUTION**

Test run, maintenance, repair and component replacement in the frequency converter are allowed to be performed by authorized specialist only!

 **WARNING**

ELECTRICAL SHOCK HAZARD

Negligence of these warnings could cause severe injury or even death!

Prior to the total discharge of the capacitors the terminal blocks of the motor must not be touched!

Prior to wiring the connectors of the device switch off the whole power supply of the device! The internal capacitor remains in charged state even after switching off the power supply. Installation is allowed to be started if the power LED has ceased lighting.

When taking the equipment from cold environment to the place of installation vapour may condense.

Prior to installation wait until the temperature of the equipment equalizes with that of the environment and the device becomes totally dry.

The appliance must not be put into operation in humid environment.

The circuitries of the frequency converter must not be modified or changed.

In switched-on state the covering of the device must not be removed and any part of it must not be touched!

The appliance must be earthed according to the standards.

 **CAUTION**

DANGER OF UNEXPECTED STARTING

Negligence of this warning could cause injury and property damage!

On switching the line power to the frequency converter, the device depending on its setting may unexpectedly start the motor.

Prior to powering the frequency converter make sure that nobody stays near to the motor and the machine and all coverings, mechanical connections, wedges, bolts and machine load are properly fastened!

 **WARNING**

FIRE HAZARD

Negligence of this warning could cause fire and injury!

The power line cable must not be connected to the output motor connections of the frequency converter!

Connecting the power line to the output connections could cause severe damage in the device.

Tighten all terminal screws to the specified tightening torque.

Loose electric connections may overheat.

Terminal Size	M3	M4	M5	M6	M8
Tightening Torque [Nm]	0.8 ÷ 1.0	1.2 ÷ 1.5	2.0 ÷ 2.5	4.0 ÷ 5.0	9.1 ÷ 11.0

 CAUTION
EQUIPMENT HAZARD Negligence of this warning could cause total damage to the device.
The device is not waterproof! Prevent the interior of the appliance from the penetration of water!
Take care that no external object (e.g. small metal part, metal powder) or liquid can get inside the device.
Avoid short circuit or ground fault at the output terminal blocks.
It is forbidden to connect any capacitor to the output. Regarding other filters, please ask the manufacturer's opinion.
Avoid using contactor at the output because the frequency converter may stop working due to switch-on overcurrent. If for other reasons using a contactor is necessary (e.g. switch-over between motors), the switchover of the output of the frequency converter during operation must be prevented by latching.
Use the shortest possible earthing conductor and avoid earth loops. (EMC)
Earthing conductors common with machines of higher power (e.g. welding machine, machine tool) must not be used.
For wiring the control unit use shielded cable. Use shielded twisted wires, and connect the shielding to the reference point of the inputs.
Observe proper electrostatic discharge procedures (ESD) when handling the frequency converter. Failure to comply may result in ESD damage to the drive circuitry.
Do not operate the device with any visible damage on it or if its any part is missing.
Do not modify the circuitry of the frequency converter to avoid damages and expiring of the warranty.
Check all the wiring to ensure that all connections are correct after installing the frequency converter and connecting other devices.

• **Cables and fuses**

At connecting the frequency converters use mains fuses and wires with cross-section as given in the table.

TYPE	Minimum fuse value (F1, F2, F3) [A]	Recomm. cable [mm ²]
V3D 0.55	6.3	0.75 ÷ 1
V3D 0.75	6.3	1 ÷ 1.5
V3D 1.1	6.3	1 ÷ 1.5
V3D 1.5	10	1.5 ÷ 2.5
V3D 2.2	10	1.5 ÷ 2.5
V3D 3	16	2.5 ÷ 4
V3D 4	16	2.5 ÷ 4

TYPE	Minimum fuse value (F1, F2, F3) [A]	Recomm. cable [mm ²]
VLD 5.5	20	2.5 ÷ 4
VLD 7.5	25	4 ÷ 6
VLD 11	30	4 ÷ 6
VLD 15	50	6 ÷ 10
VLD 22	63	10 ÷ 16

TYPE	Minimum fuse value (F1, F2, F3) [A]	Recomm. cable [mm ²]
VHD 30	80	16 ÷ 25
VHD 37	80	16 ÷ 25
VHD 45	100	25 ÷ 35
VHD 55	125	25 ÷ 35
VHD 75	160	35 ÷ 50
VHD 90	200	50 ÷ 70
VHD 110	250	70 ÷ 95
VHD 132	315	95 ÷ 120
VHD 160	355	120 ÷ 150
VHD 200	400	150 ÷ 185
VHD 250	500	240 ÷ 300

• Main and Control Circuit Wiring

• *Connecting the power line*

At connecting the power line comply with following safety measures:

- Use only circuit breakers that have been designed specifically for frequency converters.
- If an input switch is used, it is allowed to be used not more than once in every 30 minutes.
- Use an AC reactor on the input side of the drive:
 - to suppress harmonic current,
 - to improve the power factor on the power supply side,
 - when using an advancing capacitor switch.

• *Connecting the motor*

At connecting the motor comply with following safety measures:

- The output of the frequency converter has to be loaded with a three-phase motor. In case of any other load consult with the manufacturer!
- Never connect a power source to the drives output.
- Never short or ground the output terminals.
- Do not use phase correction capacitors.
- If using a contactor between the drive and motor, it should never be operated when the drive is outputting a voltage. Operating while there is voltage output can cause large peak currents, thus tripping the over current detection or damage the drive.
- For connecting the output it is recommended to use shielded cable with earthing at both ends. (EMC)
- With an output cable of longer than 30 meters, an output choke coil has to be used.
- If the cable length exceeds 200 meters, the output choke coil is not enough, because of the excessive capacitive load. In this case, a sine filter and an isolation transformer has to be used. Regarding the output choke coil or the sine filter, please ask the manufacturer's opinion.

• *Connecting the protective earth*

At connecting the earthing of the frequency converter comply with following safety measures:

- Never share the ground wire with other devices such as welding machines, etc.
- Always use a ground wire that complies with electrical equipment technical standards. Keep ground wires as short as possible. Leakage current is caused by the drive. Therefore, if the distance between the ground electrode and the ground terminal is too long, potential on the ground terminal of the drive will become unstable.
- When using more than one frequency converter, do not to loop the ground wire.
- Use earth cable of same cross-section as that of the phase conductors.

• *Connecting the control circuitry*

At connecting the control circuitry comply with following safety measures:

- Separate control circuit wiring from main circuit wiring and other high-power lines.
- The connections of the SR connectors of the control circuitry (digital output) have to be separated from other connectors of the control circuitry, unless they are used for control purposes.
- In order to avoid operation errors use twisted pair or shielded twisted pair cables for connecting the control circuitry.
- Be sure to earth the shielding with the largest possible contact area between shielding and earth connection.
- The shieldings have to be earthed at the frequency converter side of the cables.

▶ PUTTING IN OPERATON THE FREQUENCY CONVERTER FOR THE FIRST TIME

CAUTION

Prior to put in operation the frequency converter read through thoroughly the description below!

Follow all safety measures, warnings and instructions described in this manual!

Heed the safety messages in this manual.

The operating company is responsible for any injuries or equipment damage resulting from failure to heed the warnings in this manual.

- Check up the operational data of the frequency converter to be put in operation.
→ [page 5. - General features](#)
 - Install the device according to the instructions.
→ [page 6. - Mechanical installation](#)
 - Study the safety measures to be complied with.
→ [page 7. - Test run](#)
 - Connect the cables of the power line, the motor and the control elements to the corresponding terminal blocks.
→ [page 11. - Assignment and connection of the V3D terminal block](#)
→ [page 14. - Assignment and connection of the VLD / VHD terminal block](#)
 - If the device is equipped with brake check up the value and the placing of the brake resistor.
→ [page 21. - Selection guide for brake resistors](#)
 - Switch the line power to the device.
 - At devices without programming unit the motor can be started with the device's control elements according to the default setting (or the required setting).
 - At devices with programming unit check up and if necessary modify the preset parameters (rising times and fall times, minimum and maximum frequency etc.)
 - If possible, perform a trial start with unloaded motor:
 - inspect the operation of the motor,
 - in case of opposite direction of rotation interchange both phase wires of the motor to achieve the right basic direction of rotation,
- i** Interchanging the phase wires at the mains side does not influence the direction of rotation!
- with changing the reference signal (e.g. potentiometer) scan the operating frequency band,
 - try the functioning of the other controls (e.g. change of direction of rotation)
- Let the motor run with load!
 - If necessary modify the parameters (rising times and fall times, minimum and maximum frequency etc.)
 - In regulating mode tune the PID parameters
 - If the settings are appropriate save the parameters!
→ *Programmer's manual - menu 11-1-2: Save parameters*

► ASSIGNMENT AND CONNECTION OF THE V3D TERMINAL BLOCK

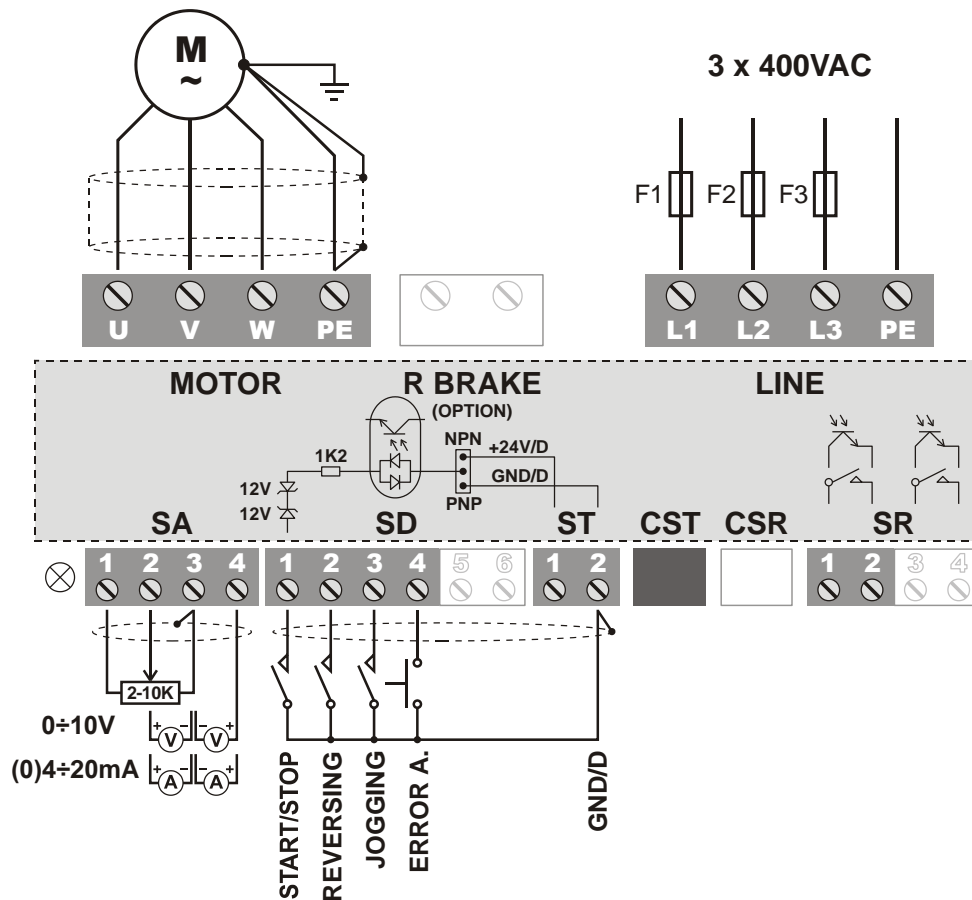

- ⊗ Three-colour LED (*green: On, yellow: Operate, red: Error*)
- SA1** +10 V potentiometer driving output (max. 6 mA) (+15 V option)
- SA2** Analogue input 1: potentiometer (2÷10 kΩ), 0÷10 V (200 kΩ), 4÷20 mA (0÷20 mA) (200 Ω)
- SA3** GND/A (reference point of the analogue inputs)
- SA4** Analogue input 2: potentiometer (2÷10 kΩ), 0÷10 V (200 kΩ), 4÷20 mA (0÷20 mA) (200 Ω)
- SD1** Digital input 1 * (factory setting: **start/stop switch**)
- SD2** Digital input 2 * (factory setting: **reversing switch**)
- SD3** Digital input 3 * (factory setting: **jogging**)
- SD4** Digital input 4 * (factory setting: **error acknowledgement**)
- SD5** Option (Digital input 5 *, or IRE(A) input)
- SD6** Option (Digital input 6 *, or IRE(B) input)
- ST1** +24 V/D supply voltage output (max. 100 mA)
In case of PNP logic the common point of the digital inputs (*K1, K2 jumpers*)
- ST2** GND/D (the reference point of the +24 V/D supply voltage output)
In case of NPN logic the common point of the digital inputs (*K1, K2 jumpers*)
- CST** Terminal serial line connector (CAN option, e.g. Master/Slave)
- CSR** Option (System serial line and/or CAN)
- SR1** } Digital output 1 ** (factory setting: **ready**)
- SR2** }
- SR3** } Option (Digital output 2 **) (factory setting: **operate**)
- SR4** }

* Switching level of the digital inputs: 0.6 to 2 mA

** Digital outputs: relay (max. 250 V AC / 1 A or 30 V DC / 0,5 A) or optocoupler (optional) (max. 30 V DC / 10 mA)

i The analogue inputs 1 and 2 (or analogue inputs 3 and 4) are not equipped with own terminals. If the configuration includes them, they are connected to the terminals of other functions (mostly to SD5 and 6)

• Jumper settings

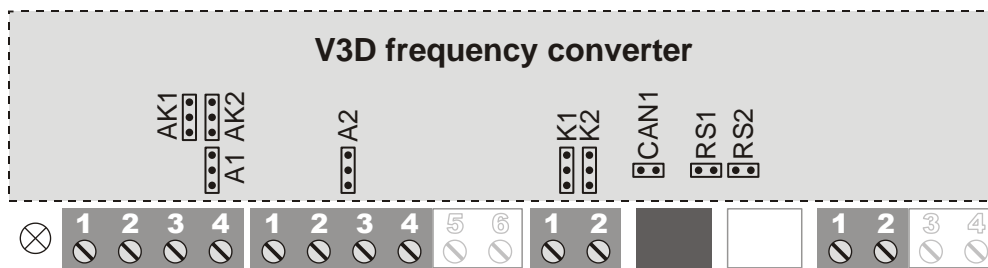

		factory settings		
AK1	Setting the analogue output 1 (option)	<input type="checkbox"/> 0÷10 V	<input type="checkbox"/> (0) 4÷20 mA	
AK2	Setting the analogue output 2 (option)	<input type="checkbox"/> 0÷10 V	<input type="checkbox"/> (0) 4÷20 mA	
A1	Setting the analogue input 1	<input type="checkbox"/> 0÷10 V	<input type="checkbox"/> (0) 4÷20 mA	
A2	Setting the analogue input 2	<input type="checkbox"/> 0÷10 V	<input type="checkbox"/> (0) 4÷20 mA	
K1	Setting the digital input 1÷4	<input type="checkbox"/> NPN logic	<input type="checkbox"/> PNP logic	} mixed setting is allowed
K2	Setting the digital input 5÷6 (option)	<input type="checkbox"/> NPN logic	<input type="checkbox"/> PNP logic	
CAN1	CAN line termination (200 Ω) (option)	<input type="checkbox"/> Not terminated	<input type="checkbox"/> Terminated	
RS1	Terminal serial line termination (200 Ω) (option)	<input type="checkbox"/> Not terminated	<input type="checkbox"/> Terminated	
RS2	System serial line termination (200 Ω) (option)	<input type="checkbox"/> Not terminated	<input type="checkbox"/> Terminated	

• Connections of the incremental rotation speed encoder (IRE) (optional) and thermal protection of the motor

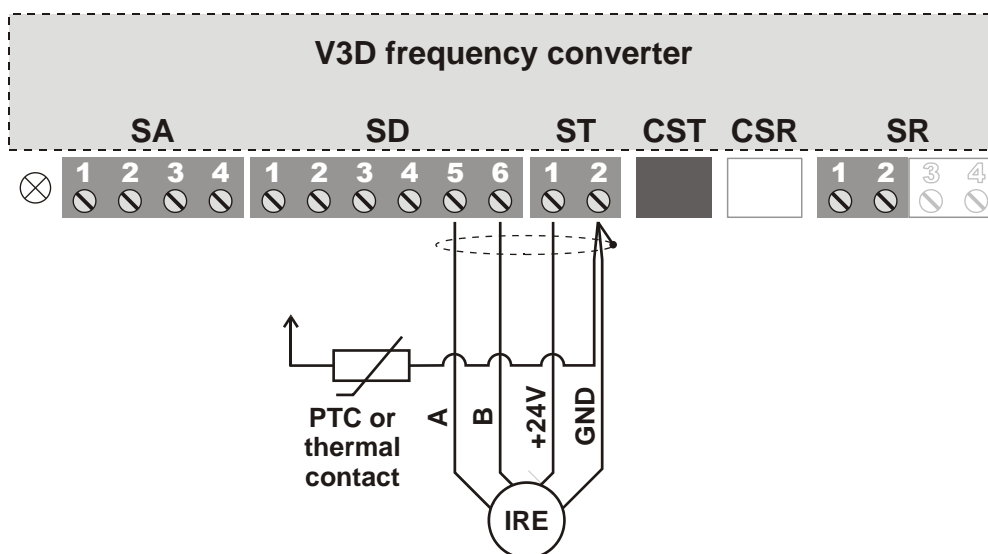

The signal device can be NPN open collector type, TTL push-pull type or an output with an output voltage of 5 to 24 V. Independently of the signal transmitter input, the further digital inputs can be operated with both negative and positive logic circuitry.

The input selected for the connection of the PTC or the thermal contact has to be provided with “External error”, “opening”.

• Connecting the brake resistor (optional, in case of built-in brake chopper)

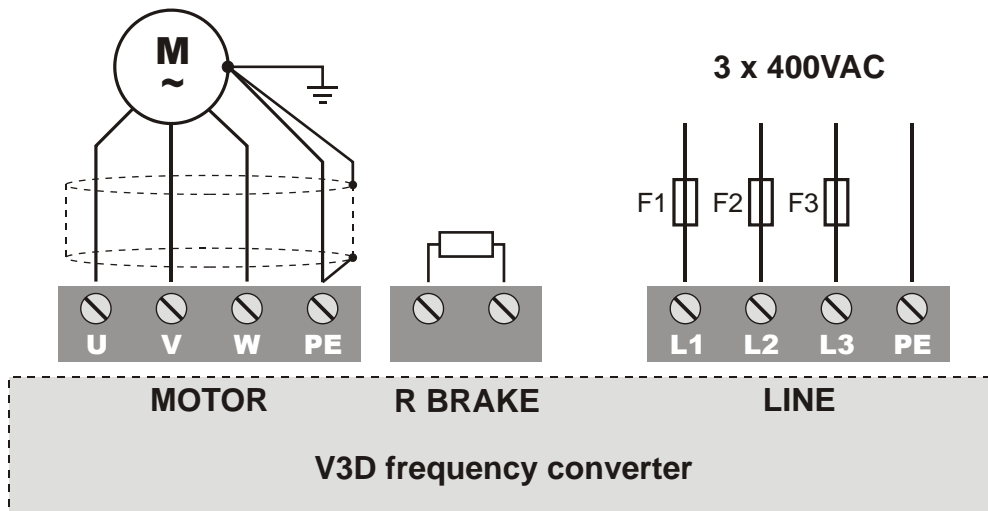

The power on the brake resistor ($P_{nominal} / 50 \div P_{nominal}$) depends on the braking time and the duty factor. [Selection guide on page 21.](#)

• Connecting a two-wire (4 ÷ 20 mA) remote transmitter

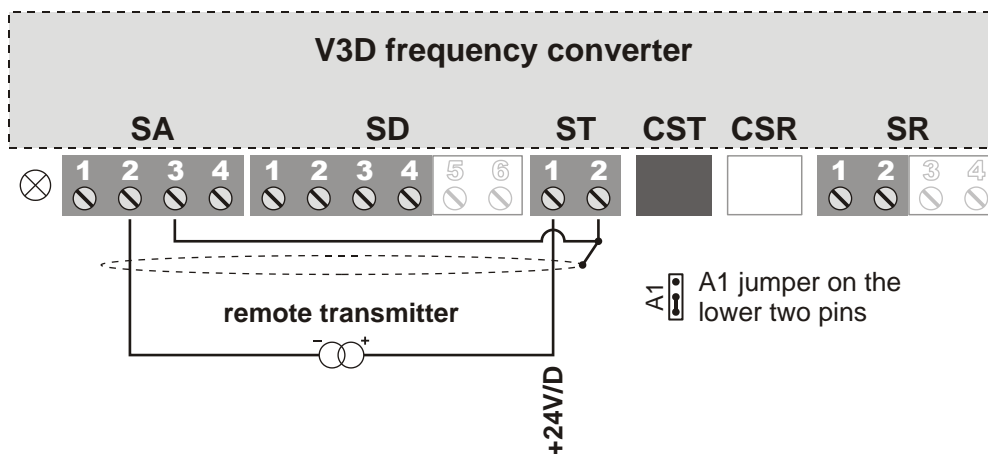

► ASSIGNMENT AND CONNECTION OF THE VLD / VHD TERMINAL BLOCK

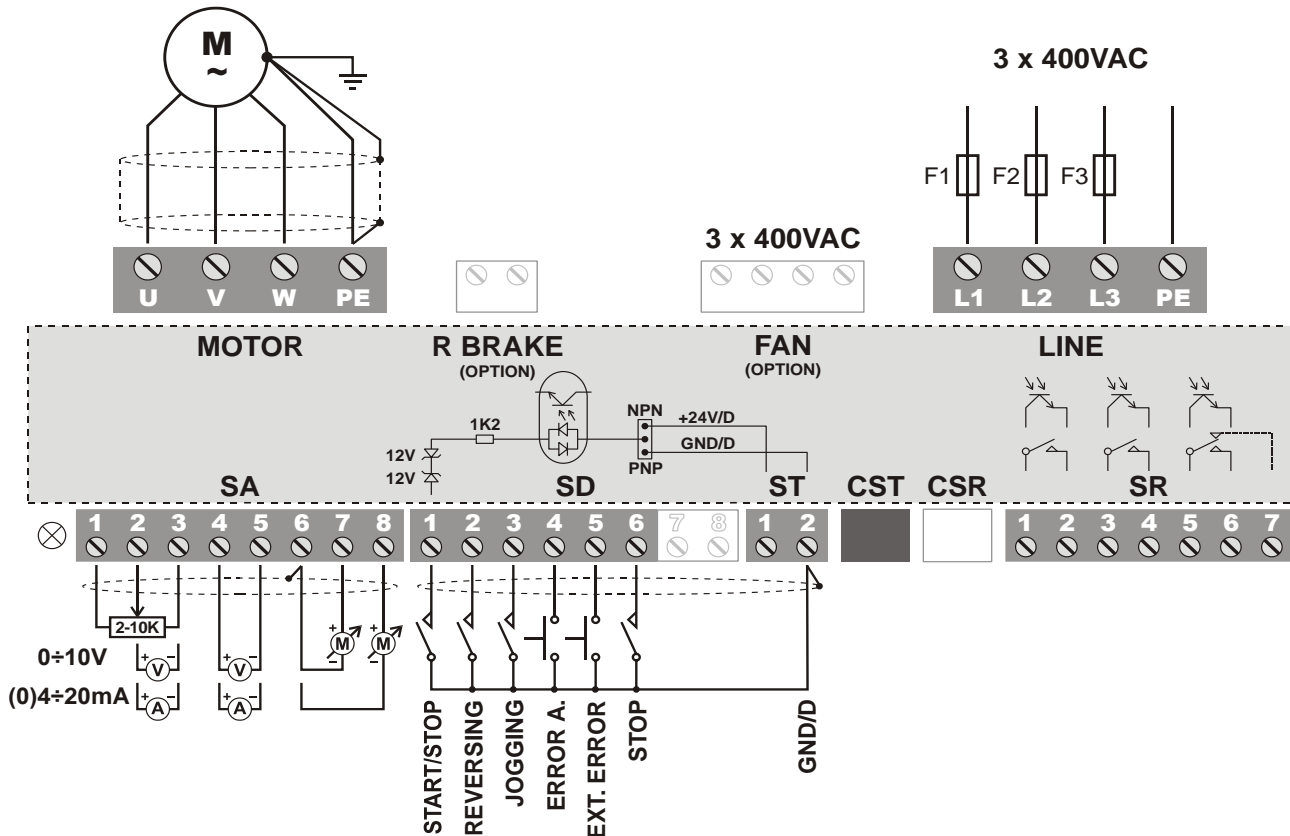

- ⊗ Three-colour LED (*green: On, yellow: Operate, red: Error*)
- SA1** +10V potentiometer driving output (max. 6 mA) (+15 V, +5 V option)
- SA2** Analogue input 1 (+): potentiometer (2÷10 kΩ), 0÷10 V (130 kΩ), 4÷20 mA (0÷20 mA) (100 Ω)
- SA3** Analogue input 1 (-): reference point (pl. GND/A)
- SA4** Analogue input 2 (+): potentiometer (2÷10 kΩ), 0÷10 V (130 kΩ), 4÷20mA (0÷20 mA) (100 Ω)
- SA5** Analogue input 2 (-): reference point (pl. GND/A)
- SA6** GND/A (reference point of the analogue inputs and outputs)
- SA7** Analogue 1 output: 0÷10V, (0)4÷20mA, (or Analogue input 3: 0÷10 V option)
- SA8** Analogue 2 output: 0÷10V, (0)4÷20mA, (or Analogue input 4: 0÷10 V option)
- SD1** Digital input 1 * (factory setting: **start/stop switch**)
- SD2** Digital input 2 * (factory setting: **reversing switch**)
- SD3** Digital input 3 * (factory setting: **jogging switch**)
- SD4** Digital input 4 * (factory setting: **error acknowledgement**)
- SD5** Digital input 5 * (factory setting: **external error**), (or reference signal IRE(A) input option)
- SD6** Digital input 6 * (factory setting: **stop switch**), (or reference signal IRE(B) input option)
- SD7** Option (Digital input 7 *, or feedback signal IRE(A) input)
- SD8** Option (Digital input 8 *, or feedback signal IRE(B) input)
- ST1** +24 V/D supply voltage output (max. 100 mA)
In case of PNP logic the common point of the digital inputs (*K1, K2, K3 jumpers*)
- ST2** GND/D (the reference point of the +24 V/D supply voltage output)
In case of NPN logic the common point of the digital inputs (*K1, K2, K3 jumpers*)
- CST** Terminal serial line connector (CAN1 option)
- CSR** Option (System serial line and/or CAN2)
- SR1** } Digital output 1 ** (factory setting: **ready** - closing / **error** - opening)
- SR2** }
- SR3** } Digital output 2 ** (factory setting: **operate** - closing / **stop** - opening)
- SR4** }
- SR5** } Digital output 3 ** (factory setting: **brake control**) (optional for VLD 5,5 ÷ 11)
- SR6** }
- SR7** Digital output 3: In case of a relay contact closed in rest position (option)

* Switching level of the digital inputs: 0.6 to 2 mA

** Digital outputs: relay (max. 250 V AC / 1 A or 30 V DC / 0,5 A) or optocoupler (optional) (max. 30 V DC / 10 mA)

• Jumper settings

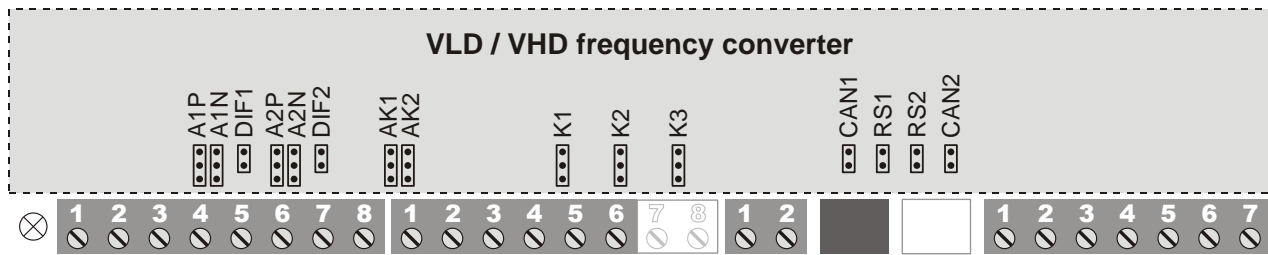

		factory settings		
A1P, A1N	Setting the analogue input 1	0÷10V	(0)4÷20mA	
DIF1	Setting the analogue input 1	Normal (- point: GND/A)	Differential	
A2P, A2N	Setting the analogue input 2	0÷10V	(0)4÷20mA	
DIF2	Setting the analogue input 2	Normal (- point: GND/A)	Differential	
AK1	Setting the analogue output 1	0÷10V	(0)4÷20mA	
AK2	Setting the analogue output 2	0÷10V	(0)4÷20mA	
KOZOS1 (K1)	Setting the digital input 1-4	NPN logic	PNP logic	} mixed setting is allowed
KOZOS2 (K2)	Setting the digital input 5-6	NPN logic	PNP logic	
KOZOS3 (K3)	Setting the digital input 7-8 (option)	NPN logic	PNP logic	
CAN1	CAN1 line termination (200Ω) (option)	Not terminated	Terminated	
CAN2	CAN2 line termination (200Ω) (option)	Not terminated	Terminated	
RS1	Terminal serial line termination (200Ω) (option)	Not terminated	Terminated	
RS2	System serial line termination (200Ω) (option)	Not terminated	Terminated	

• High voltage terminal block

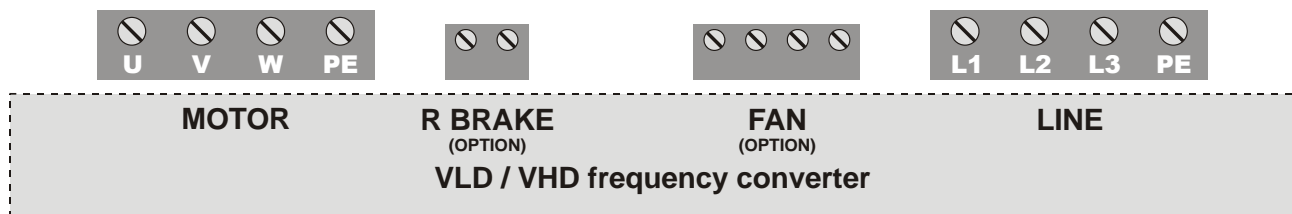

Ventilator terminal block (3 x 400 V AC):

For models VHD 45 to 250 (option)

Switched together with the cooling ventilators of the frequency converter. Available for connecting external cooling ventilator (e.g. for cooling the control cabinet),

At models VHD 90 to 250, PE will be connected to a grounding screw.

- Connections of the incremental rotation speed encoder (IRE) (optional) and thermal protection of the motor

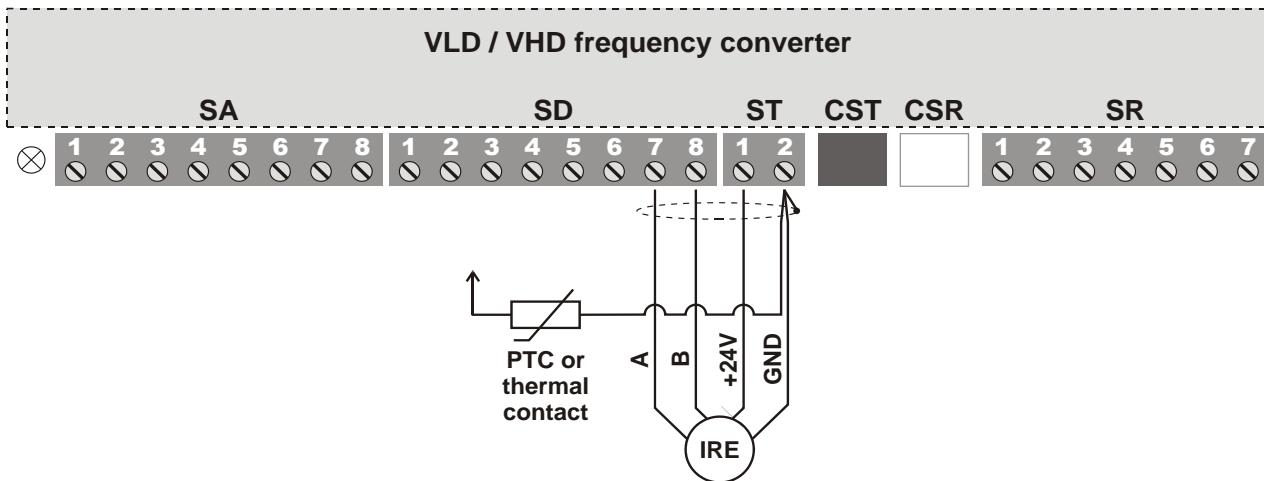

The signal device can be NPN open collector type, TTL push-pull type or an output with an output voltage of 5 to 24 V. Independently of the signal transmitter input, the further digital inputs can be operated with both negative and positive logic circuitry.

The input selected for the connection of the PTC or the thermal contact has to be provided with “External error”, “opening”.

- Connecting the brake resistor (optional, in case of built-in brake chopper)

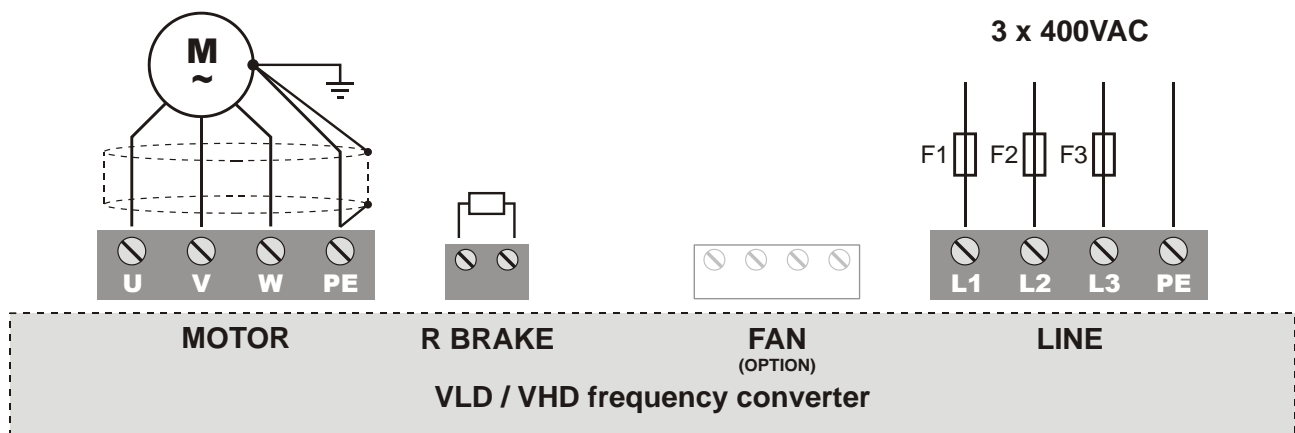

The power on the brake resistor ($P_{nominal} / 50 \div P_{nominal}$) depends on the braking time and the duty factor. [Selection guide on page 21.](#)

• Connecting a two-wire (4 ÷ 20 mA) remote transmitter

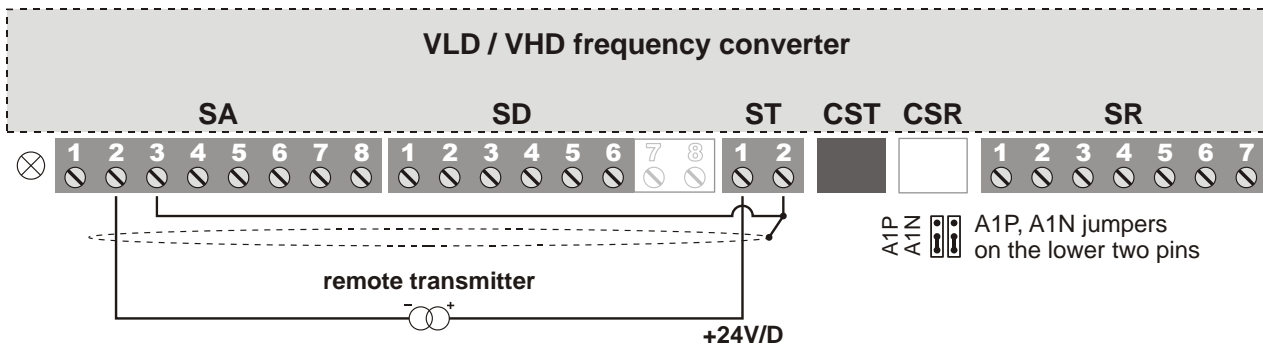

• ±10 V analogue input (option)

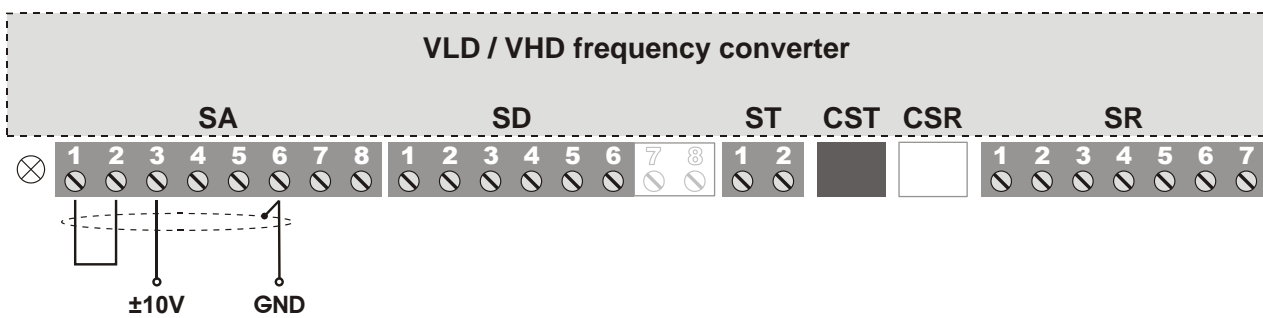

▶ OPERATING THE CONVERTER

The source of the reference signal can be:

- external or front panel potentiometer,
- 0÷10 V,
- 4÷20 mA (0 ÷ 20 mA),
- front panel controlling terminal,
- external or front panel programming terminal (varying with the type),
- RS 485 serial line,
- CAN bus,
- motor potentiometer

The source of the logical control signals can be:

- terminal blocks,
- front panel controlling terminal,
- external or front panel programming terminal (varying with the type),
- RS 485 serial line,
- CAN bus

• Programming terminal

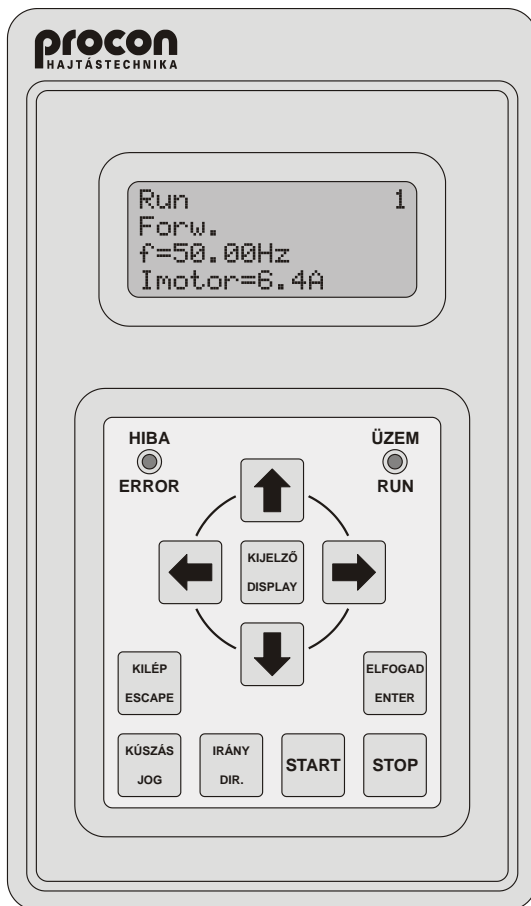

- It comprises a 4x16 character display and 11 push buttons in two groups.

Upper group: ↑, ↓, ←, →, DISPLAY, ESCAPE, ENTER,

Bottom group: JOG, DIRECTION, START, STOP.

Operation of the push buttons of the upper (programming) group:

The push buttons of the upper group permit entering and selecting data in the Parameter setting mode and in the Display mode.

Operation of the push buttons of the bottom (control) group:

The push buttons of the bottom group permit controlling the operation of the frequency converter if the terminal has been preset for the control. The bottom four push buttons work independently from the upper ones. Therefore if the terminal is the preset operating control, the motor can be stopped or started etc. even during entering data.

- Default setting in Display mode
(The structure of displaying can optionally be varied: in any line any parameter can be displayed.)

In line **1**: the three parts of the status are displayed:

- Motor status: **Run / Stop**,
- Dynamic status acknowledgement (e.g. **I limit**),
- Identification of the frequency converter (e.g. **1**).

In line **2**: Direction **Forw. / Backw.**

In line **3**: Frequency (e.g. **f=50.00Hz**),

In line **4**: Motor current (e.g. **Imotor=6.4A**)

- It can be used as a built-in unit or in casing as a stand alone unit.

• Operating from the computer

The frequency converter can be connected to the computer through RS485-T line using RS 232 / 485 or USB / RS 485 adapter (interface).

Here the TermOnly program permits setting the frequency converter from the computer and provides a user interface with the same look as that of the programming terminal.

The ProContact program beyond handling the frequency converter permits reading out, modifying and archiving the actual parameter set as well as reading out and archiving the event- and error log.

Both programs are available on CD as attachment of the adapter (interface) unit or can be downloaded from www.procon.hu.

• **Controlling terminal**

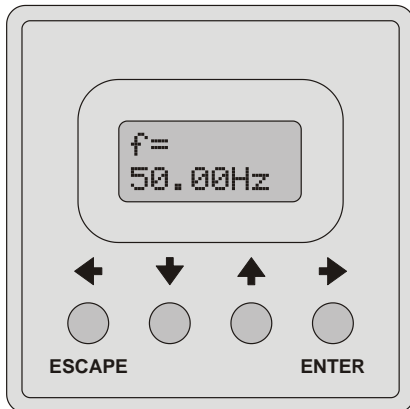

- **This terminal allows programming, displaying 1 parameter and reference signal generation.**
- Equipped with a 2x8 character display and 4 push buttons.
- Reading in display mode: first row - the name of a displayable parameter (e.g. f=), second row - its value (e.g. **50,00Hz**). The display can be stepped with the ↑ and ↓ arrows.
- Reading in programming mode: first row - the parameter's ordinal number in the menu (e.g. **3-1-1**), second row - (in case of a variable parameter) the value of the actual parameter (e.g. **5.00s**), that can be modified with the push buttons.
- The terminal can be used built in the front panel of the frequency converter only!

• **Functions of the push buttons**

- ← (Escape)
 - Change between display mode and programming mode
 - Parameter setting mode: shift the cursor to the left
 - Repeated push: exit parameter setting mode without saving (until the cursor blinks)
 - At error display: displaying the cause of the error
- ↓
 - Display mode: scrolling the displayed variables downward
 - Programming mode: moving in the menu downward
 - Parameter setting: decreasing the value or scrolling the selector switches downward
 - With selected terminal motor potentiometer: decreasing the reference signal
 - With enabled motor potentiometer start / stop: Stop
- ↑
 - Display mode: scrolling the displayed variables upward
 - Programming mode: moving in the menu upward
 - Parameter setting: increasing the value or scrolling the selector switches upward
 - With selected terminal motor potentiometer: increasing the reference signal
 - With enabled motor potentiometer start / stop: Start
- (Enter)
 - Programming mode: starting the parameter setting
 - Parameter setting mode: shift the cursor to the right
 - Repeated push: save parameter value (until the cursor blinks)
 - Acknowledgement at error

► PROGRAMMING (controlling terminal)

• Programming procedure

- ← (Escape) ▪ Changing from display mode to programming mode
 - ↓ ↑ ▪ Moving between the menu items
 - (Enter) ▪ Starting parameter setting
 - ← ↓ ↑ → ▪ Parameter setting
 - (Escape) ▪ Repeated push: save parameter value (until the cursor blinks)
- or
- ← (Enter) ▪ Repeated push: exit parameter setting mode without saving (until the cursor blinks)

• Quick menu

Submenu	Description, further submenus	Value, range	Default setting	Unit
Parameter - 1 - 2-1-1 control Tup	In default setting the time needed to reach fmax starting from 0 Hz (in control mode).	0,05 - 3276,7	Depending on type	s
Parameter - 2 - 3-1-1 control Tdown	In default setting the time needed to reach f = 0 Hz starting from fmax (in control mode).	0,05 - 3276,7	Depending on type	s
Parameter - 3 - 6-4 motor In	The durably permitted motor current.	0,5 - dep. on type	Depending on type	A
Parameter - 4 - 8-1 f maximum	Maximum output frequency. <i>* default setting is 100 Hz for V3D frequency converters without controlling terminal</i>	0,1 - 1050,0	50,0 *	Hz
Parameter - 5 - 8-2 f minimum	Minimum output frequency.	0,1 - 1000,0	1,0	Hz
Parameter - 6 - 7-2-1 U boost	Starting voltage given to the motor at standing start.	0,5 - dep. on type	Depending on type	V
Parameter - 7 - 10-14 active menu	Allows access to the whole menu system for the controlling terminal. After switching on/off automatically returns to handling the quick menu.	quick all	quick	

► DRIVING TECHNOLOGY SUPPLEMENTS

• 4x16 character display

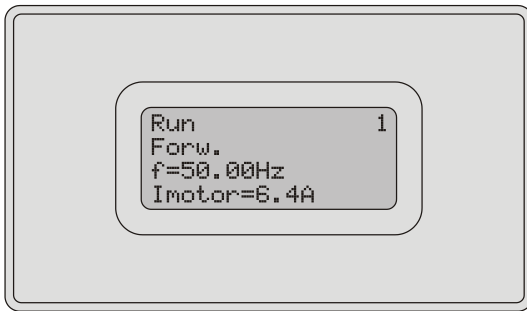

- Displays the display of the programming terminal.
- The display can operate together with the terminal, since it only receives data and does not answer through the serial line.
- The display can be used in built-in form (VHD) or as an externally mounted unit (e.g. to the door of the control cabinet).

• Potentiometer (2 ÷ 10 kΩ, linear)

Wiring:

Frequency conv. terminal blocks	Potentiometer
SA 1 (+10 V)	1
SA 2 (An. IN 1.)	2
SA 3 (GND/A)	3



• Selection of the brake resistors at dynamic braking

The power on the brake resistor depends on the braking time and the duty factor. ($P_{nominal} / 50 \div P_{nominal}$)
 The necessary power is determined by the braking time and the duty factor.

(→ see: Programming manual, support for dimensioning the brake resistor)

Frequency converter type	Resulting resistance
V3D 0.55 - 1.1	$\geq 200 \Omega$
V3D 1.5 - 4	$\geq 100 \Omega$
VLD 5.5	$\geq 50 \Omega$
VLD 7.5 - 11	$\geq 25 \Omega$
VLD 15	$\geq 20 \Omega$
VLD 22	$\geq 13 \Omega$
VHD 30 - 37	$\geq 11 \Omega$
VHD 45 - 55	$\geq 8 \Omega$
VHD 75 - 90	$\geq 4,5 \Omega$
VHD 110 - 160	$\geq 3,3 \Omega$
VHD 200	$\geq 2,2 \Omega$
VHD 250	$\geq 1,6 \Omega$



- 100 W wire-wound resistors (50÷200 Ω)
- 500 W wire-wound resistors (50÷100 Ω)
- 2÷4 kW cased brake resistor modules (12,5÷100 Ω)

⚠ CAUTION

The brake resistors are imposed to high voltages of 660 V DC.

The appliance must be installed and wired very carefully because of heat developing and for proper electric shock protection.

For wiring use cables with heat-resisting coating.

▶ **MAINTENANCE**

At normal operation the device needs no maintenance. Depending on the surroundings inspect regularly the ventilators, and at models built in cabinet also the condition of the filter cartridge.

Inspect the screwed fastenings according to the local maintenance regulations, but at least once a year.

▶ **GUARANTEE AND REPAIR**

The products come with a guarantee period of 24 months.

 CAUTION
The guarantee covers normal operation only. In case of improper storage, improper use or unauthorized intervention the guarantee terminates.
Repair will be accomplished both within the guarantee period and after in the manufacturer's premises, the appliance has to be transported there by the user.

▶ **DISPOSAL**

• **Disposing of packaging**

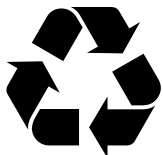

Sort the packaging before you dispose of it.

Dispose of paperboard and cardboard with the recycled paper service and wrappers with appropriate collection service.

• **Disposing of obsolete equipment**



Do not dispose of the product with the house-hold waste.

Instead, hand in the product to a collection center for old electrical or electronic appliances.

Upon request, the manufacturer will take over the appliance returned to its site and dispose of it.

► FREQUENCY CONVERTER SELECTION GUIDE

0.55	0.75	1.1	1.5	2.2	3	4	5.5	7.5	11	15	22	30	37	45	55	75	90	110	132	160	200	250	(kW)

TYPE	Output power [kW]	Nominal current [A]	Peak current [A]	Mass [kg]	Physical dimensions [mm]				Fastening screws
					Width	Length	Height	Fastening	

Three phase, 3 x 380 ÷ 440 V AC input

V3D 0.55	0.55	1.7	3	2	128	210	91	90 x 200	4 x M4
V3D 0.75	0.75	2.6	4	2.5	128	210	142	90 x 200	4 x M4
V3D 1.1	1.1	3.2	5	2.5	128	210	142	90 x 200	4 x M4
V3D 1.5	1.5	4.2	6	3	128	240	150	90 x 230	4 x M4
V3D 2.2	2.2	6	9	3	128	240	150	90 x 230	4 x M4
V3D 3	3	8	12	4	128	280	150	90 x 265	4 x M4
V3D 4	4	10	14	4	128	280	150	90 x 265	4 x M4

VLD 5.5	5.5	14	19	8	190	290	220	170 x 280	4 x M5
VLD 7.5	7.5	18	30	12	190	390	220	170 x 380	4 x M5
VLD 11	11	26	37	12	190	390	220	170 x 380	4 x M5
VLD 15	15	35	57	14	190	490	220	170 x 470	4 x M5
VLD 22	22	48	75	20	290	490	220	260 x 470	4 x M6

VHD 30	30	62	95	38	300	590	300	260 x 550	4 x M8
VHD 37	37	75	115	38	300	590	300	260 x 550	4 x M8
VHD 45	45	90	135	65	400	740	300	360 x 700	4 x M8
VHD 55	55	110	150	65	400	740	300	360 x 700	4 x M8
VHD 75	75	150	220	80	500	740	300	460 x 700	4 x M8
VHD 90	90	180	255	85	500	790	300	460 x 750	4 x M8
VHD 110	110	220	310	110	500	1100	335	460 x 900	4 x M10
VHD 132	132	260	360	115	500	1100	335	460 x 900	4 x M10
VHD 160	160	320	450	120	500	1100	365	460 x 900	4 x M10
VHD 200	200	400	540	120	500	1100	410	460 x 1040	4 x M10
VHD 250	250	500	670	125	500	1100	410	460 x 1040	4 x M10

► PERIPHERAL EQUIPMENT SELECTION GUIDE

ITEM	V3D	VLD	VHD
3 x 400 V line voltage	●	●	●
Built-in mains noise suppressor	●	●	●
IP20 cabinet	●	●	●
IP54 cabinet	○	○	○
Analogue input 1 - 2	●	●	●
Analogue input 3 - 4	○	○	○
±10V analogue input	-	○	○
Analogue output 1 - 2	○	●	●
Digital input 1 - 4	●	●	●
Digital input 5 - 6	○	●	●
Digital input 7 - 8	-	○	○
Digital output 1	●	●	●
Digital output 2	○	●	●
Digital output 3	-	○	●
RS-485 serial line 1 (Terminal)	●	●	●
RS-485 serial line 2 (System)	○	○	○
USB / RS 485 interface	○	○	○
RS 485 / 485 interface (optical light cable type)	○	○	○
USB / RS 485 interface (optical light cable type)	○	○	○
CAN bus 1	○	○	○
CAN bus 2	-	○	○
Reception of incr. rotation speed encoder 1	○	○	○
Reception of incr. rotation speed encoder 2	-	○	○
Built-in dynamic brake	○	○	○
Brake resistor	○	○	○
Mains (input) choke	○	○	○
Output (motor) choke	○	○	○
Stand-alone programming terminal (4 x 16)	○	○	○
Built-in programming terminal	-	-	○
Built-in controlling terminal (2 x 8)	○	●	●
Built-in display (4 x 16)	-	-	○
External display	○	○	○
Built-in potentiometer	○	○	○
External potentiometer	○	○	○

Markings	● Basic config.	○ Optional	- Not applicable
----------	-----------------	------------	------------------

PROCON Hajtástechnika Kft.

H-1047 Budapest, Kisfaludy u. 4.

Tel./fax: +36 1 370 9699

+36 1 379 5387

e-mail: procon@procon.hu

info@procon.hu

Internet: www.procon.hu

